



The Key to Healthy Air

HETA School Recuperator

80 m³/h optimal airflow

- Dedicated for rooms with up to 30 people
- Excellent air filtration system
- Humidity control system
- Best value
- Automatic control



A+ / C



What exactly is the HETA School recuperator?

Our device supplies classrooms and other spaces with fresh, purified air. The CO₂ and humidity levels are controlled automatically, providing the very best studying and working conditions. The air movement is imperceptible, and the energy consumption or heat loss minimal.

HETA School is also the most affordable air handling unit within the Premium+ class in Poland.



OPERATION AREA

1 room



FOR ROOM CAPACITY UP TO

30 people



NOISE VOLUME

39 dB(A)



ASSEMBLY TIME

1 day

Learn, work, relax

HETA School provides a comfortable microclimate in rooms for up to 30 people.

This applies to:

- classrooms
- meeting rooms
- small restaurants

Quiet operation

The noise the recuperator emits while working in a 700 m³ room is as quiet as a whisper – just 39 dB. This allows everyone inside to concentrate comfortably.

Quick assembly

It takes just one day to assemble and mount the device. In a single room one recuperator unit is installed under the ceiling and one air intake-exhaust system is mounted in the window frame.



Excellent air filtration

IN ITS CLASS

- The recuperator can be equipped with both an active carbon filter and a high grade HEPA 13 filter
- The air is being purified from smog, bacteria and allergens (filters to be changed on a regular basis)



Automatic control

HETA School saves energy, automatically adjusting its operating mode according to the conditions in the room:

- The number of people and the CO₂ level
- The temperature and humidity



What makes the HETA School special?

Caring for comfort



Humidity and temperature adjustment



Maintaining an optimum CO₂ level



Imperceptible airflow



Odour removing technology



Can be combined with an optional additional air heater-cooler unit

Take a deep breath

and focus on what's really important

Let's clear the air

As of today, most Polish classrooms are not ventilated. Unfortunately opening a window does not solve the problem, as there usually is a large number of students in a rather small room. Additionally, due to poor air quality and high humidity levels, fungi and surface moulds rapidly spread in schools.

The CO₂ level in these classrooms is on average three times higher than the norm recommended by the WHO.

Breathing air with such a high carbon dioxide content, children become sleepy and start losing focus, which impairs their cognitive abilities. The problem is as serious for the adults, who find it difficult to concentrate during long meetings in crowded conference rooms.

How does HETA School optimize the air quality in crowded rooms?



Air exchange

- Maintains a steady CO₂ level (800–1000 ppm)
- Provides a healthy and comfortable humidity level. It's recovery system automatically dries or humidifies the air in the room, adjusting to the current conditions.
- Reduces the risk of getting infected from a sick person in the same room.
- Eliminates odours and volatile organic compounds (VOC).



Filtration

The supplied air is efficiently purified by a series of high-grade filters.

From both the supplied fresh air and air extracted from the room the filters eliminate:

- Smog (99% particulate matter $\leq 1 \mu\text{m}$ and 99% PM_{2,5-10} μm)
- carcinogens,
- allergens,
- bacteria,
- viruses.

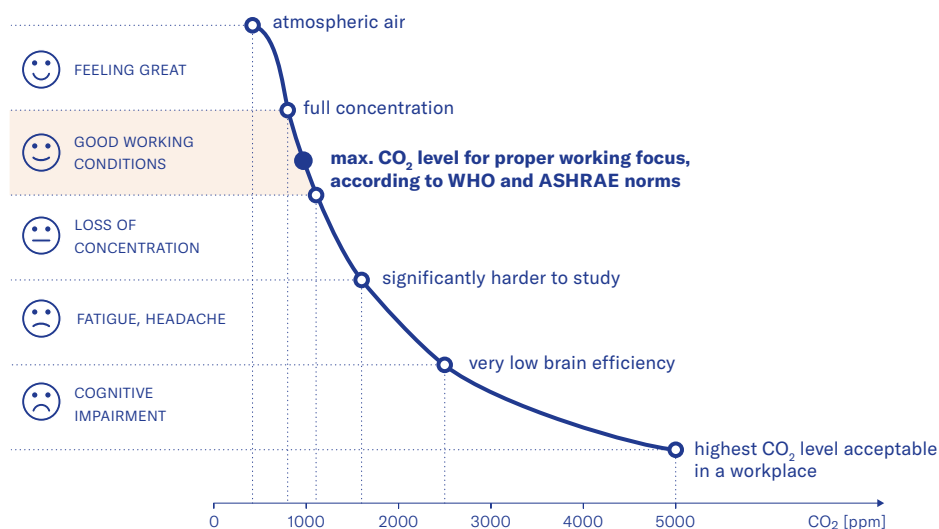

source
A. Murkowski, E. Skórska
Czy zwiększona zawartość dwutlenku węgla w powietrzu ma wpływ na sprawność intelektualną człowieka?
[Does the increased content of carbon dioxide in the air affect the intellectual performance of a person?],
"Kosmos. Problemy nauk Biologicznych" 2016, vol. 65
<http://kosmos.icm.edu.pl/PDF/2016/631.pdf>

COST EFFECTIVE COMFORT

Humidity recovery

The device uses an alternating air flow system. This prevents the condensate from forming on the surface and the heat exchanger from freezing in the winter time. It also enables humidity recovery from air extracted from the room.

ECO-PURIFYING

Air recirculation mode

If the CO₂ level in the room is below 1000 ppm, the recuperator cleans the inside air without supplying fresh air from outside the building. This makes the use of air conditioning directly on the air ducts even more effective and cost efficient.

DIRECT SAVINGS

Heat exchanger's bypass

When heat recovery is not needed or during passive cooling, the outer air flow bypasses the heat exchanger to save energy. It's especially useful during chilly summer nights. After a long, hot day the device uses outside air to cool the room down.

WHAT YOU GIVE IS WHAT YOU GET

Heat recovery

During the heating season, the device will use the temperature of the extracted air from the room to heat the fresh air it supplies. Not only it makes everyone inside stay warm – it's a great way to save money!

CONVENIENT CONTROL

BMS connection

HETA School's control system can connect with building management systems. No need to buy an extra communication module!

HETA School is a Premium+ class recuperator

Discover its benefits!



Technical specification

Optimal airflow	900 m ³ /h
Maximum airflow	1175 m ³ /h (100 Pa)
Energy class	A+/C
Specific energy consumption	42,25 kWh/m ² /year
Ventilator's power use at the maximum airflow	400 W
Type of ventilation unit	bidirectional
Type of heat recovery system	recuperative
Type of heat exchanger	countercurrent
Nominal supply voltage	230 V AC/50 Hz
Acoustic pressure level emitted from the casing	39 dB(A)*

Outside dimensions (length × width × height)	178.2 × 134.2 × 47.6 cm
Ventilation connection dimensions (diameter)	31.5 cm
Weight	75 kg

Filters	H13 and active carbon
Bypass	100%, insulated
Automatics	A BMS compatible control system, automatic adjustment to the room air quality and temperature, control system based on CO ₂ and humidity levels.
Operating temperature range	5–45 °C
Permissible humidity	25–90%
Fuse type	16 A
Degree of protection class	IP 40

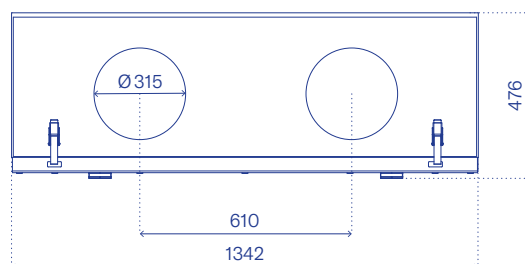
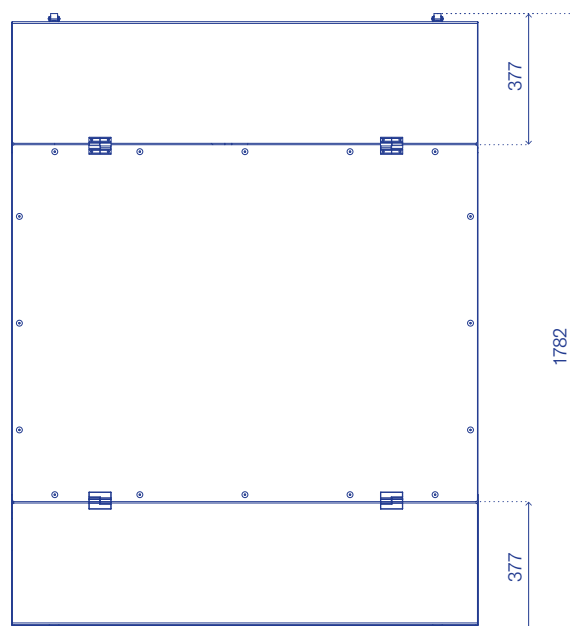

Performance

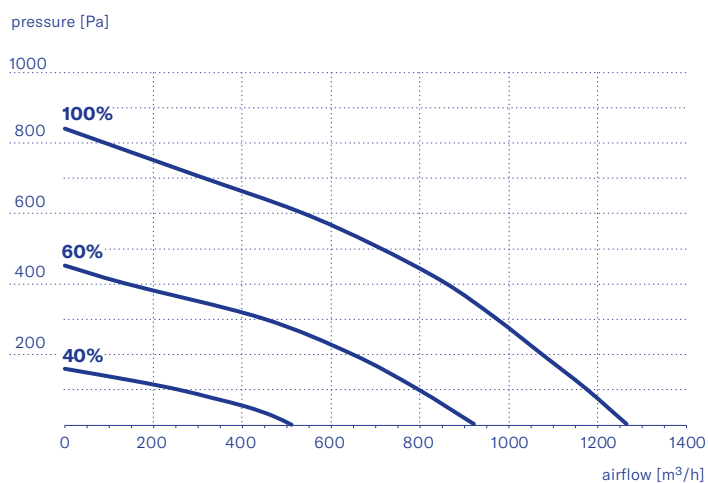

Acoustic pressure levels (L_{pA}) *

Frequency	63 Hz	125 Hz	250 Hz	500 Hz	1 kHz	2 kHz	4 kHz	8 kHz	Total
dB	23,3	30,8	27,9	28,8	26	22,4	14,2	0,6	39 dB(A)

* Measurement carried out in 1 m distance from the casing with an airflow of 700 m³/h

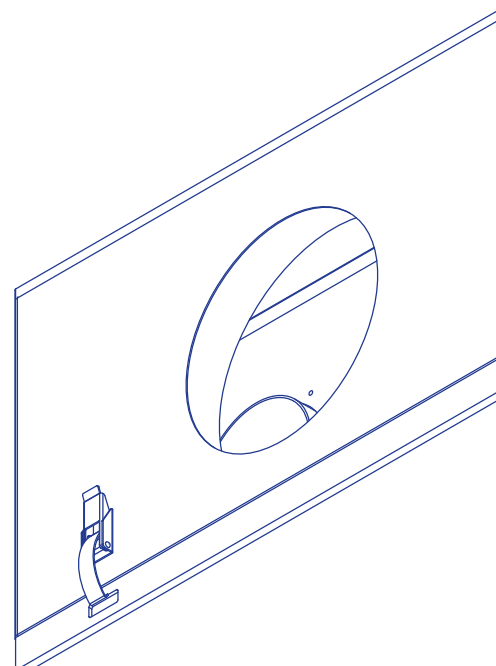

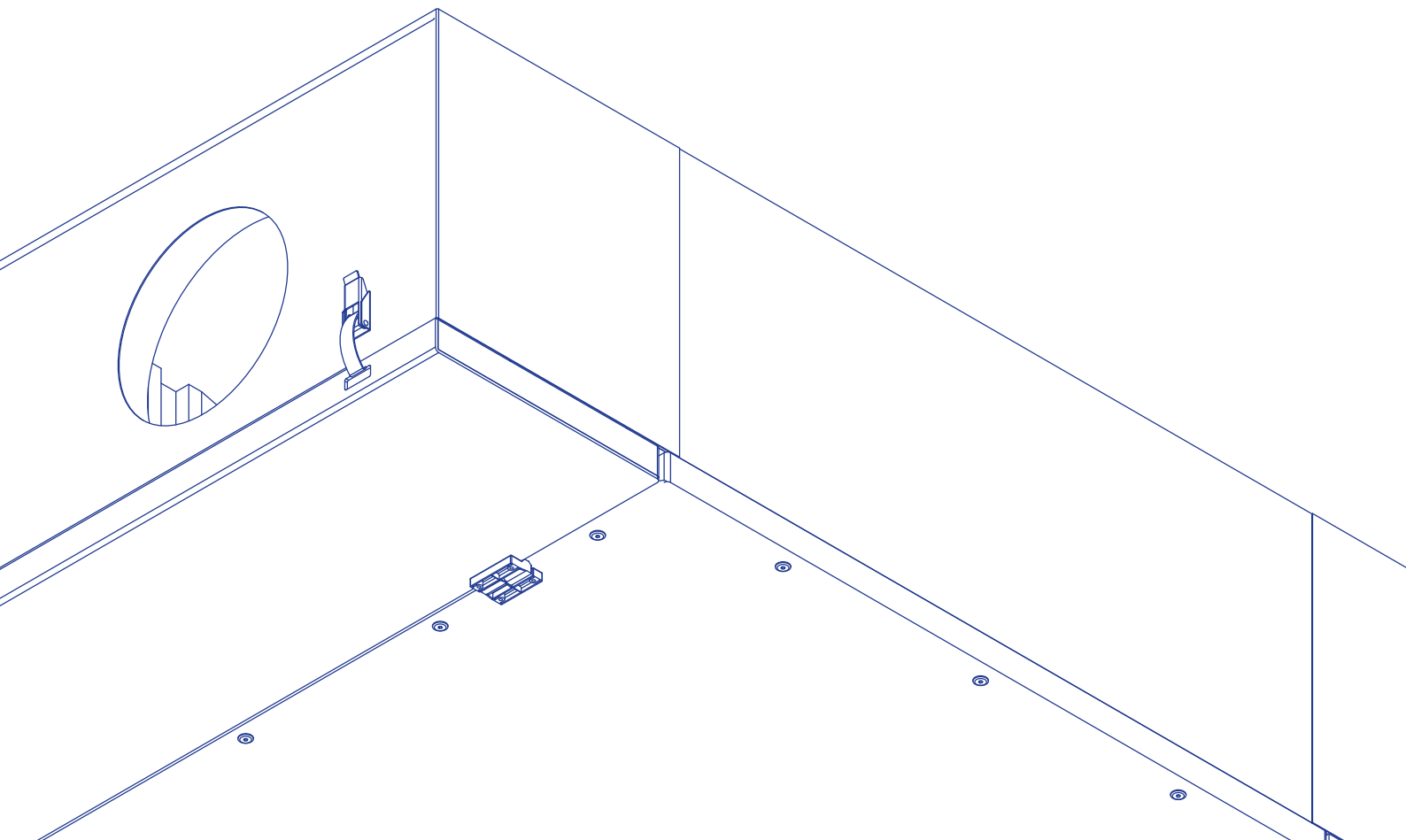

*Discover supreme
air quality.*

*Create
a comfortable
and healthy
work and study
space.*



21stopni.pl

Creating innovative ventilation systems.
We focus on aspects of health, ecology and inclusivity.
The members of our team won numerous awards
for their previous projects.

© 21 STOPNI, NOVEMBER 2023

Contact

Jacek Kostrzewa
biuro@21stopni.pl
+48 601 362 581