



The Key to Healthy Air

# HETA Home Recuperator

150 m<sup>3</sup>/h optimal airflow

- Dedicated to 60–250 m<sup>2</sup> spaces
- Excellent air filtration
- Humidity control system
- Automatic control
- Upgrades the energy class of your house



**A+ / C**

The HETA Home Recuperator is being created as part of the “Ventilation systems for schools and houses” project by the National Centre for Research and Development.



# House energy class upgrade

According to the EU EPBD directive: “As of 2030, all new buildings in the EU must be zero-emission. To ensure more harmonised standards across Member States, minimum energy performance standards will be set at EU level.”\*

Usable energy for heating and ventilation is crucial for a building’s energy class. Our high-efficiency recovery system reduces thermal energy demand, thereby increasing home value.

\* [www.europarl.europa.eu/RegData/etudes/ATAG/2023/739377/EPRS\\_ATA\(2023\)739377\\_EN.pdf](http://www.europarl.europa.eu/RegData/etudes/ATAG/2023/739377/EPRS_ATA(2023)739377_EN.pdf)



## Heat recovery

During the heating season, the device will use the temperature of the extracted air from the room to heat the fresh air it supplies. Energy recovery occurs without the need for a heater-cooler unit, resulting in even greater overall energy savings.



## Free cooling

When heat recovery is not needed or during passive cooling, the outer air flow bypasses the heat exchanger to save energy. It’s especially useful during chilly summer nights. After a long, hot day the device uses outside air to cool the room down.

## How it works

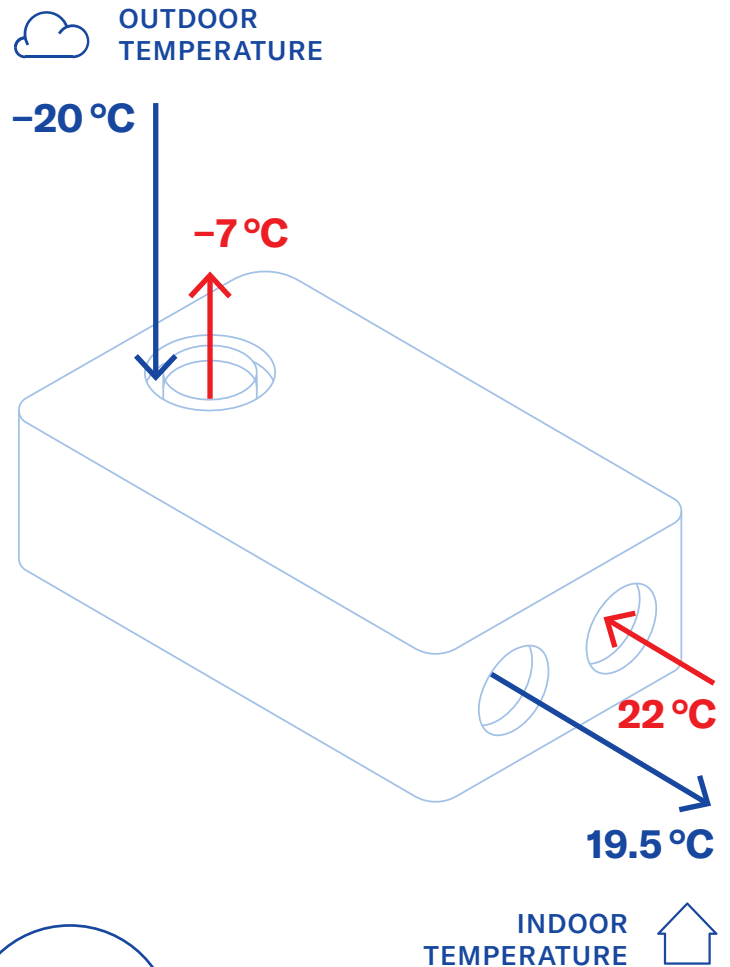

recovers  
**89%**  
heat energy

# The key to healthy air

“Despite ongoing overall improvements in air quality, levels of air pollutants above EU standards are seen across Europe and air pollution remains a major health concern for Europeans.”\*

Our device supplies the entire house with fresh, purified air. The humidity and CO<sub>2</sub> levels are controlled automatically, providing the very best living conditions.

\* [www.eea.europa.eu/publications/europes-air-quality-status-2023](http://www.eea.europa.eu/publications/europes-air-quality-status-2023)



## Filtration

The supplied air is efficiently purified by a series of high-grade filters. From both the supplied fresh air and air extracted from the room the filters eliminate:

- pollen
- spores
- cement dust
- fly ash
- bacteria and germs on host particles
- oil fumes and agglomerated soot
- tobacco smoke
- metallic-oxide smoke



## Humidity recovery





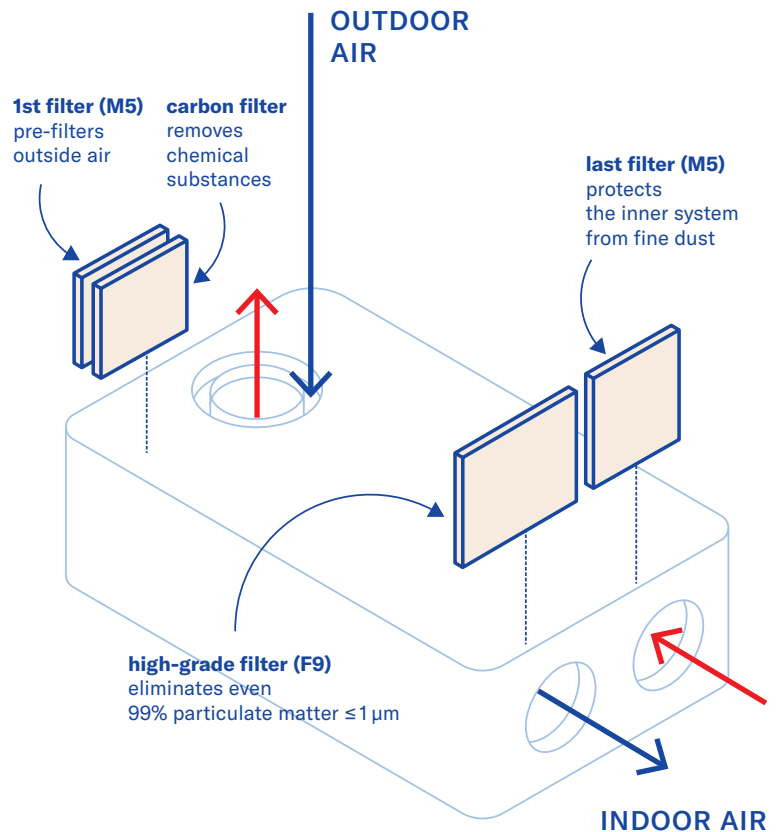

The device uses an alternating air flow system. This prevents the condensate from forming on the surface and the heat exchanger from freezing in the winter time. It also enables humidity recovery from air extracted from the room.

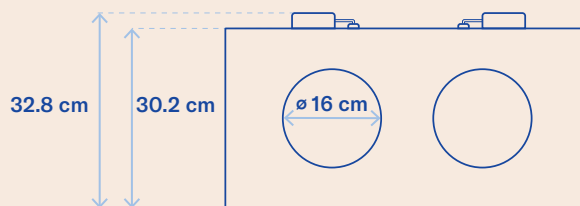
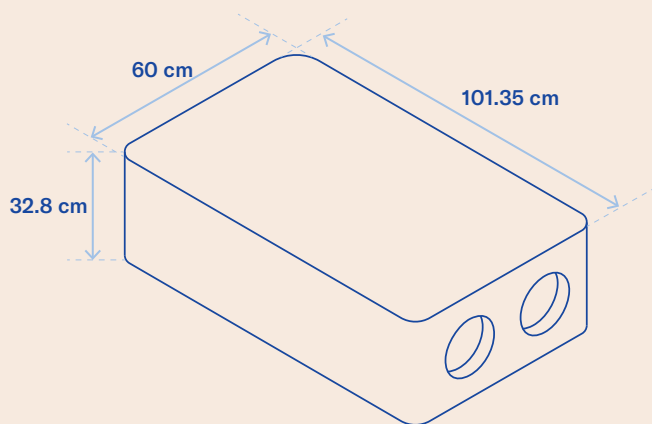
## How it works



removes  
**99%**  
PM  $\leq 1 \mu\text{m}$



 <b>Operating space</b> <b>60–250</b> m <sup>2</sup>	 <b>Heat recovery</b> <b>89</b> %	 <b>Annual Heating Saved</b> <b>76</b> kWh/m <sup>2</sup> /year
 <b>Noise volume</b> <b>37</b> db(A)	 <b>Humidity recovery</b> <b>95</b> %	 <b>PM ≤1 reduction</b> <b>99</b> %

Optimal airflow	150 m <sup>3</sup> /h
Maximum airflow	300 m <sup>3</sup> /h
Energy class	A+/C
EU eco-design	ErP 2018
Ventilator's power use at the maximum airflow	120 W
Nominal supply voltage	230 V AC/50 Hz
Type of ventilation unit	bidirectional
Type of heat recovery system	recuperative
Type of heat exchanger	counterFlow
Acoustic pressure level emitted from the casing	37 dB(A)

Outside dimensions (length × width × height)	101.5 × 61 × 32.8 cm
Ventilation connection dimensions (diameter)	16 cm
Weight	47 kg

Filters	F9, M5 and activated carbon
Bypass	100%, insulated

Automatics	A BMS-compatible control system, with automatic adjustments for room air quality and temperature. The control system operates based on CO <sub>2</sub> and humidity levels.
Operating temperature range	5–45 °C
Permissible humidity	25–90%
Fuse type	10 A
Degree of protection class	IP 24

### Performance

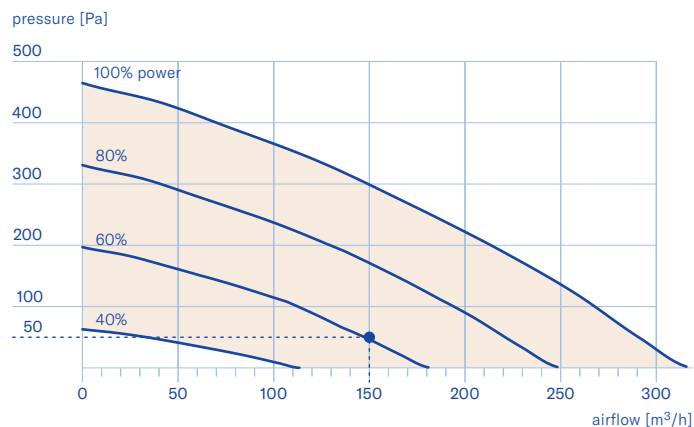

### Contact us!